

Electric Forklifts

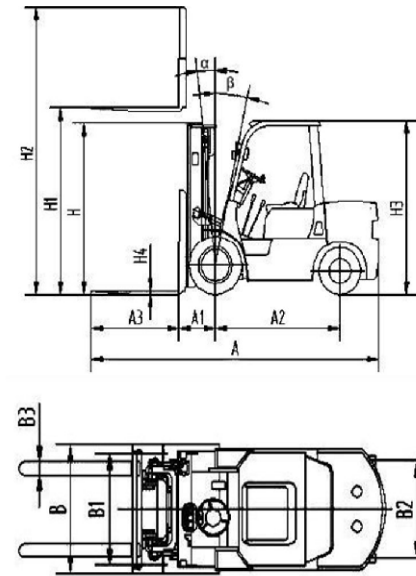

Specifications

| Model | HH30-C1 | FB25 | FB30 | FB35 | LG25B111 | E1030GS(3 Wheel) | E1330GS(3 Wheel) | E1530GS(3 Wheel) | |
|--------------------------|----------------------------|----------------------------|----------------------------|----------------------------|----------------------------|---------------------------|---------------------------|---------------------------|--------|
| Power Type | Battery | Battery | Battery | Battery | Battery | Battery | Battery | Battery | |
| Rated Capacity | 3000kg | 2500kg | 3000kg | 3500kg | 2500kg | 1000kg | 1300kg | 1500kg | |
| Load Center | 500mm | 500mm | 500mm | 500mm | 500mm | 500mm | 500mm | 500mm | |
| Lifting Height | 3000mm | 3000mm | 3000mm | 3000mm | 3000mm | 3000mm | 3000mm | 3000mm | |
| Fork Size(L×W×H) | 1070×122×40mm ³ | 1070×122×40mm ³ | 1070×125×45mm ³ | 1070×125×45mm ³ | 1070×120×40mm ³ | 950×100×35mm ³ | 950×100×35mm ³ | 950×100×35mm ³ | |
| Tilting Angle F/R(α°/β°) | 43263 | 43263 | 43263 | 43263 | 43230 | 43136 | 43136 | 43136 | |
| Overall Dimension | Length(without fork) | 2310mm | 2285mm | 2560mm | 2560mm | 3380mm(with fork) | 2530mm | 2530mm | 2465mm |
| | Overall Width | 1150mm | 1150mm | 1230mm | 1230mm | 1265mm | 917mm | 917mm | 917mm |
| | Height When Mast Lowered | 1985mm | 1995mm | 2120mm | 2120mm | 2108mm | 1995mm | 1995mm | 1995mm |
| | Height When Mast Lifted | 4030mm | 4030mm | 4160mm | 4160mm | / | 3949mm | 3949mm | 3949mm |
| | Safeguard Height | 2130mm | 2145mm | 2250mm | 2250mm | 2140mm | 1980mm | 1980mm | 1980mm |
| Min. Turning Radius | 2120mm | 2000mm | 2315mm | 2315mm | 2090mm | 1348mm | 1348mm | 1348mm | |
| Front Overhang | 470mm | 445mm | 480mm | 480mm | 448mm | / | / | / | |
| Trend(Front/Rear) | 960mm/950mm | 955mm/950mm | 1000mm/980mm | 1000mm/980mm | 1037mm/954mm | / | / | / | |
| Min. Ground Clearance | 110mm | 110mm | 120mm | 120mm | 100mm | 90mm | 90mm | 90mm | |
| Wheelbase | 1450mm | 1400mm | 1700mm | 1700mm | | 1090mm | 1090mm | 1090mm | |
| Travel Speed(Laden) | 11.5km/h | 13.5km/h | | | 13.5km/h | 6.2km/h | 6.2km/h | 6.2km/h | |

| | | | | | | | | | |
|----------------------|--------------|--------------|-----------------|-----------------|----------------|--------------|-----------|-----------|-------|
| Lifting Speed(Laden) | 260mm/s | 240mm/s | 300mm/s | 280mm/s | 280mm/s | 132mm/s | 132mm/s | 132mm/s | |
| Gradeability(Laden) | 15% | 12.50% | 15% | 15% | 13% | 6% | 6% | 6% | |
| Service Weight | 4100kg | 3820kg | 5100kg | 5350kg | 4180kg | 1840kg | 2050kg | 2190kg | |
| Tire Type | Pneumatic | Air Tires | / | / | / | PU | PU | PU | |
| Tire Size | Front Tire×2 | 7.00-12-12PR | 21×8-19-16PR | 28×9-15-12PR | 7.00-12-12PR | 23×9-10-12PR | / | / | / |
| | Rear Tire×2 | 18×7-8-14PR | 18×7-8-14PR | 18×7-8-14PR | 18×7-8-14PR | 18×7-8-14PR | / | / | / |
| Motor | Driven Motor | 6.5kw | 8kw | 16.6/9kw(SME) | 16.6/9kw(SME) | 11kw | 2.5kw | 2.5kw | 2.5kw |
| | Lift Motor | 8.6kw | 8.6kw | 13.5/22kw(SME) | 13.5/22kw(SEM) | 11kw | 4.5kw | 4.5kw | 4.5kw |
| Battery(Standard) | 48V/620Ah | 45V/565Ah | 80V/500Ah | 80V/500(550)Ah | 48V/600Ah | 24V/300Ah | 24V/350Ah | 24V/400Ah | |
| Controller | CURTIS DC | / | SME/ZAPI/CURTIS | SME/ZAPI/CURTIS | ZAPI | / | / | / | |
| Operating Pressure | 17.5Mpa | 17.5Mpa | / | / | / | / | / | / | |

Diesel Forklifts

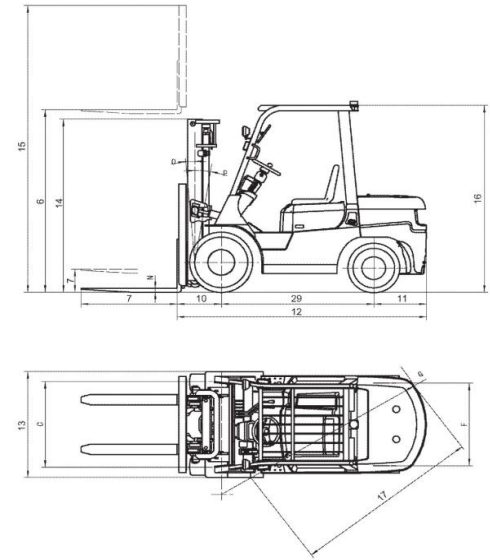

Specifications

| Model | | FD35T-C4WE3 | CPCD30 | FD20 | FD25 | FD30 | FD35 | FD50 | HNF35Y |
|--------------------------|--------------------------|----------------------------|----------------------------|----------------------------|----------------------------|----------------------------|----------------------------|----------------------------|----------|
| Power Type | | Diesel | Diesel | Diesel | Diesel | Diesel | Diesel | Diesel | Diesel |
| Rated Capacity | | 3500kg | 3000kg | 2000kg | 2500kg | 3000kg | 3500kg | 5000kg | 3500kg |
| Load Center | | 500mm | 500mm | 500mm | 500mm | 500mm | 500mm | 600mm | 500mm |
| Lifting Height | | 3000mm | 3000mm | 3000mm | 3000mm | 3000mm | 3000mm | 3000mm | 3000mm |
| Fork Size(L×W×H) | | 1220*122*45mm ³ | 1070×125×45mm ³ | 1070×120×45mm ³ | 1070×120×40mm ³ | 1070×125×45mm ³ | 1070×125×50mm ³ | 1220*150*60mm ³ | / |
| Tilting Angle F/R(α°/β°) | | 43385 | 43263 | 43263 | 43263 | 43263 | 43263 | 43263 | / |
| Overall Dimension | Length(without fork) | 3081mm | 2770mm | 2600mm | 2600mm | 2730mm | 2770mm | 3180mm | 2956mm |
| | Overall Width | 1600mm | 1225mm | 1150mm | 1150mm | 1225mm | 1225mm | 1485mm | 1600.5mm |
| | Height When Mast Lowered | 2330mm | 2070mm | 1995mm | 1995mm | 2045mm | 2045mm | 2390mm | 2330mm |
| | Height When Mast Lifted | 4305mm | 4225mm | 4030mm | 4030mm | 4150mm | 4150mm | 4295mm | 4305mm |
| | Safeguard Height | 2278mm | 2160mm | 2070mm | 2070mm | 2090mm | 2090mm | 2270mm | 2276mm |
| Min. Turning Radius | | 3120mm | 2410mm | 2310mm | 2310mm | 2440mm | 2480mm | 2865mm | / |
| Front Overhang | | 601mm | / | 470mm | 470mm | 475mm | 480mm | / | / |
| Min. Ground Clearance | | 219mm | 120mm | 120mm | 120mm | 135mm | 135mm | 100mm | 270mm |
| Wheelbase | | 1880mm | 1700mm | 1600mm | 1600mm | 1700mm | 1700mm | 2000mm | 1880mm |
| Travel Speed(Laden) | | 18km/h | 18km/h | 19km/h(unladen) | 19km/h(unladen) | 19km/h(unladen) | 19km/h(unladen) | 18km/h | 22km/h |

| | | | | | | | | | |
|----------------------|-----------------|-----------------|----------------|--------------------|--------------------|--------------------|--------------------|----------------|-------------------|
| Lifting Speed(Laden) | | 485mm/s | 400mm/s | 530mm/s | 530mm/s | 440mm/s | 420mm/s | 380mm/s | 450mm/s |
| Gradeability(Laden) | | 0.45 | 0.2 | 0.2 | 0.2 | 0.2 | 0.2 | 0.25 | 0.16 |
| Service Weight | | 5545kg | 4280kg | 3590kg | 3790kg | 4300kg | 4500kg | 7000kg | 5180kg |
| Tire Size | Front Tire×2 | 14-17.5-14PR | 28×9-15-14PR | 7.00-12-12PR | 7.00-12-12PR | 28×9-15-12PR | 28×9-15-12PR | 300-15-18PR | 14-17.5-14PR |
| | Rear Tire×2 | 10.0/75-15.3PR | 6.5-10-10PR | 6.00-9-10PR | 6.00-9-10PR | 6.50-10-10PR | 6.50-10-10PR | 7.00-12-12PR | 27×10-12-12PR |
| Battery | | 12V/90Ah | 12V/100Ah | 12V/80Ah | 12V/80Ah | 12V/80Ah | 12V/80Ah | 12V/80Ah | 12V/90Ah |
| Engine | Model | 4TNE98-BQFLC | C240 | C490BPG-6A | C490BPG-236 | C490BPG-236 | A495BPG-13 | mitsubishi S6S | 4TNE98-BQFLC |
| | Rated Output | 42.1kw/2300rpm | 34.5kw/2500rpm | 36.8kw/2650rpm | 40kw/2650rpm | 40kw/2650rpm | 42kw/2650rpm | 52kw/2300rpm | 42.1kw/2300rpm |
| | Rated Torque | 196.3Nm/1700rpm | 134Nm/1800rpm | 148Nm/1800-1900rpm | 160Nm/1800-2000rpm | 160Nm/1800-2000rpm | 174Nm/1800-2000rpm | 248Nm/1700rpm | 186-206Nm/1700rpm |
| | No. of Cylinder | 4 | / | 4 | 4 | 4 | 4 | 6 | / |
| | Displacement | 3.318L | 2.369L | 2.540L | 2.670L | 2.670L | 2.980L | 4.996L | / |
| Bore×Stroke | | 98mm×110mm | / | 90mm×100mm | 95mm×105mm | 90mm×105mm | 95mm×105mm | / | 98mm×110mm |
| Fuel Tank Capacity | | 55L | / | 60L | 60L | 60L | 60L | 80L | 55L |

Propane Forklifts

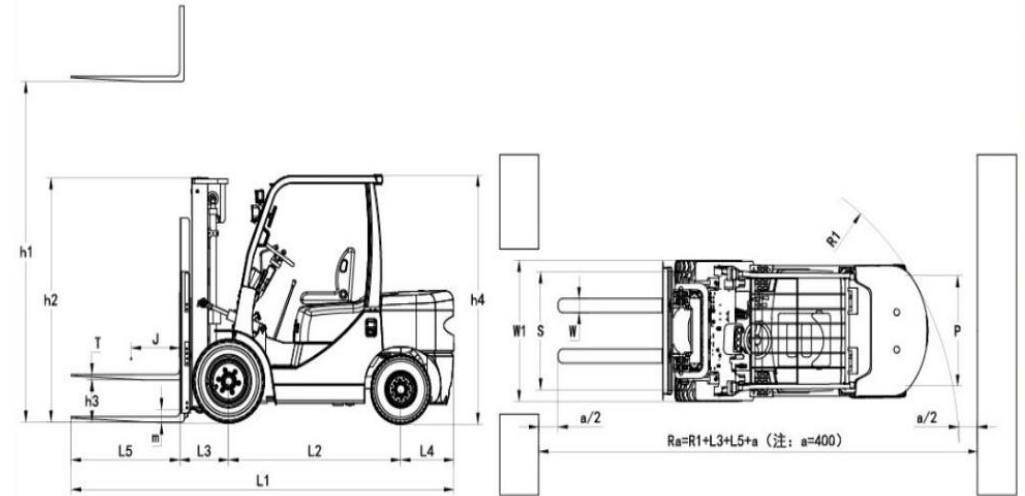

Specifications

| Model | FL15 | FL18 | FL25 | FL30 | FD25 | SF30Y | SF35Y | CPQ10 |
|--------------------------|---------------------------|---------------------------|----------------------------|----------------------------|----------------------------|----------------------------|----------------------------|---------------------------|
| Power Type | LPG/Gasoline | LPG/Gasoline | LPG/Gasoline | LPG/Gasoline | LPG/Gasoline | LPG/Gasoline | LPG/Gasoline | LPG/Gasoline |
| Rated Capacity | 1000kg | 1800kg | 2500kg | 3000kg | 2500kg | 3000kg | 3500kg | 1000kg |
| Load Center | 500mm | 500mm | 500mm | 500mm | 500mm | 500mm | 500mm | 500mm |
| Lifting Height | 3000mm | 3000mm | 3000mm | 3000mm | 3000mm | 3000mm | 3000mm | 3000mm |
| Fork Size(L×W×H) | 920x120x35mm ³ | 920x120x35mm ³ | 1070x122x40mm ³ | 1070x125x45mm ³ | 1070x122x40mm ³ | 1070x122x45mm ³ | 1070x122x45mm ³ | 920x122x40mm ³ |
| Tilting Angle F/R(α°/β°) | 43263 | 43263 | 6/12 | 43263 | 43263 | 43263 | 43263 | 43263 |
| Overall Dimension | Length(without fork) | 2295mm | 2295mm | 2570mm | 2825mm | 2570mm | 3779mm | 2180mm |
| | Overall Width | 1086mm | 1086mm | 1175mm | 1230mm | 1175mm | 1220mm | 1080mm |
| | Height When Mast Lowered | 1995mm | 1995mm | 1990mm | 2065mm | 1990mm | 2070mm | 1995mm |
| | Height When Mast Lifted | 3940mm | 3940mm | 4000mm | 4260mm | 4000mm | 4272mm | 4020mm |
| | Safeguard Height | 2040mm | 2040mm | 2120mm | 2170mm | 2120mm | 2140mm | 2075mm |
| Min. Turning Radius | 2055mm | 2055mm | 2240mm | 2600mm | 2240mm | 2400mm | 2450mm | 1890mm |
| Front Overhang | 420mm | 420mm | 473mm | 545mm | 473mm | 495mm | 495mm | / |
| Trend(Front/Rear) | / | / | 970mm/970mm | 1000mm/970mm | 970mm/970mm | 1000mm/980mm | 1000mm/980mm | 890mm/920mm |
| Min. Ground Clearance | 110mm | 110mm | 110mm | 120mm | 110mm | 110mm | 135mm | 95mm |
| Wheelbase | 1400mm | 1400mm | 1600mm | 1800mm | 1600mm | 1700mm | 1700mm | 1400mm |

| | | | | | | | | | |
|----------------------|-----------------|-----------------|-----------------|-----------------|-----------------|-----------------|-----------------|-----------------|----------------|
| Travel Speed(Laden) | | 15km/h(unladen) | 15km/h | 19km/h | 20km/h | 19km/h | 20km/h | 20km/h | 13.5km/h |
| Lifting Speed(Laden) | | 450mm/s | 440mm/s | 470mm/s | 470mm/s | 470mm/s | 520mm/s | 520mm/s | 450mm/s |
| Gradeability(Laden) | | 20% | 20% | 20% | 20% | 20% | 20% | 20% | 20% |
| Service Weight | | 2870kg | 3050kg | 3750kg | / | 3750kg | 4300kg | 4560kg | 2340kg |
| Tire Size | Front Tire×2 | 6.5-10-10PR | 6.5-10-10PR | 7.00-12-12PR | 28×9-15-12PR | 7.00-12-12PR | 28×9-15-14PR | 28×9-15-14PR | 6.50-10-10PR |
| | Rear Tire×2 | 5.00-8-10PR | 5.00-8-10PR | 6.00-9-10PR | 6.50-10-10PR | 6.00-9-10PR | 6.50-10-10PR | 6.50-10-10PR | 5.00-8-8PR |
| Battery | | 12V/80Ah | 12V/80Ah | 12V/90Ah | 12V/90Ah | 12V/90Ah | / | / | 12V/80Ah |
| Engine | Model | Nissan K21 | Nissan K21 | NISSAN K25 | Nissan K25 | Nissan K25 | NISSAN K25 | NISSAN K25 | NISSAN |
| | Rated Output | 31.2kw/2250rpm | 31.2kw/2250rpm | 37.4kw/2300rpm | 37.4kw/2300rpm | 37.4kw/2300rpm | 37.4kw/2300rpm | 37.4kw/2300rpm | 31.2kw/2250rpm |
| | Rated Torque | 143.7Nm/1600rpm | 143.7Nm/1600rpm | 176.5Nm/1600rpm | 176.5Nm/1600rpm | 176.5Nm/1600rpm | 176.5Nm/1600rpm | 176.5Nm/1600rpm | 143Nm/1600rpm |
| | No. of Cylinder | 4 | 4 | 4 | 4 | 4 | 4 | 4 | 4 |
| | Displacement | 2.065L | 2.065L | 2.488L | 2.488L | 2.488L | 2.488L | 2.488L | 2.065L |
| Bore×Stroke | | 89mm×83mm | 89mm×83mm | 89mm×100mm | 89mm×100mm | 89mm×100mm | 89mm×100mm | 89mm×100mm | / |
| Fuel Tank Capacity | | 60L | 60L | 60L | 70L | 60L | / | / | 38L |
| Working Pressure | | / | / | 17.5Mpa | 17.5Mpa | 17.5Mpa | / | / | 17.5Mpa |